

Counter Balance Power Stacker

FIPL-119B

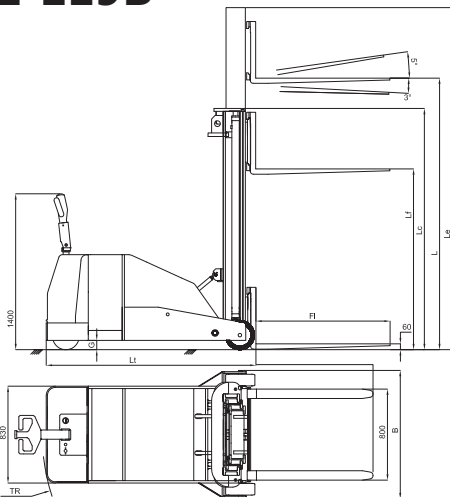

MODEL	FIPL-119B			
Product Size				
Model Number	FIPL-CBST-10	FIPL-CBST-15	FIPL-CBST-20	FIPL-CBST-30
Capacity (Kg)	1000	1500	2000	3000
Operating Type	Stand-On / Walkie			
Load Center C mm	600			
Tyre	Polyurethane/Rubber			
Drive Wheel Size mm	ø230x70			
Load Wheel mm	ø200x100			
Lower Height of Fork mm	60			
Overall Length mm	2405	2805	3205	3700
Length to face of Fork Lt mm	1410	1810	2200	2700
Overall Width B mm	1120/1200/1220			
Fork Diemensions s/e/l mm	1000x80x45 / 1000x100x45			
Fork Width Max mm	800			
Minimum Ground Clearance G mm	80			
Turning Radius Without Platform Wa mm	1330	1700	2250	
Max. Lifitng Height	1600/2500/3000/			
Travel Speed Loaded/ Unloaded km/h	5/5.5			
Parking Brake	Electromagnetic			
Drive Motor Kw	1.5 Brushless			
Lift Motor Rating Kw	2.2 / 3			
Battery Voltage / Nominal Capacity V/Ah	24/280 / 24/330			
Type of Drive Control	MOSFET Control			
Reverse Horn	Yes			

Note: There may be any specification/dimensional change. If these specifications are critical, the proposed application should be discussed.