

Edge Dock Leveler

FIPL-DL-191A

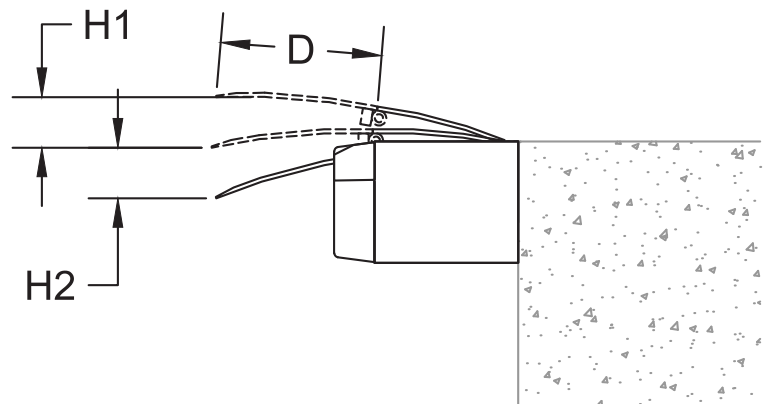

SIDE VIEW

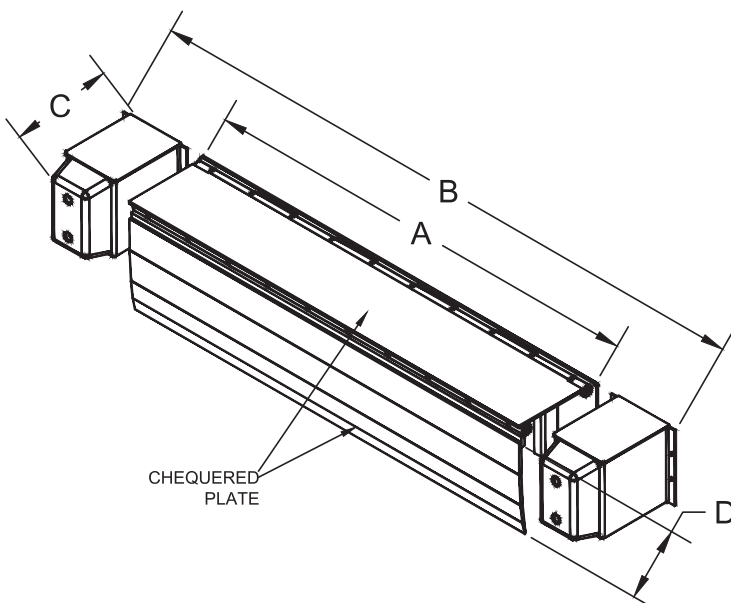

CAPACITY	: 6 / 8 / 10 TON
DECK LENGTH	: A 1830
OVERALL LENGTH	: B 2590
OVERALL WIDTH	: C 380
LIP WIDTH	: D 400
WORKING HEIGH	: +H1 / -H2 +125 / -125
OPERATION	: MANUAL /ELECTRO-HYDRAULIC

*DIMENSIONS CAN BE CUSTOMIZED AS PER REQUIREMENT.

Edge Dock Leveler

FIPL-DL-191A



MODEL	FIPL-191A	
Product Size		
Capacity (Kg)	4000 Kg / 6000 Kg / 8000 Kg	As per requirement
Platform Size (LxW) (mm)	1830 x 350	As per requirement
Lip Size (LxW) (mm)	1830 x 400	As per requirement
Type	Mechanical / Electro - Hydraulic	As per requirement
Working Range (mm)	+/- 125	As per requirement
Cylinders	One for Deck, One for Lip (only in Electro-Hydraulic)	As per requirement
Power Pack	1 - 1.5 HP (only in Electro-Hydraulic)	As per requirement
Motor	3 Phase (only in Electro-Hydraulic)	As per requirement
Features	<ul style="list-style-type: none"> - Economical and space saving solution to bridge the gap between your factory floor and Vehicle floor. - Low power consumption. - Rubber Bumpers at both side of EOD. 	
*Tolerance in lifting and technical Specs.	+/- upto 20mm	

Note: There may be any specification/dimensional change. If these specifications are critical, the proposed application should be discussed.