

Forklift Drum Grab

FIPL-DG360

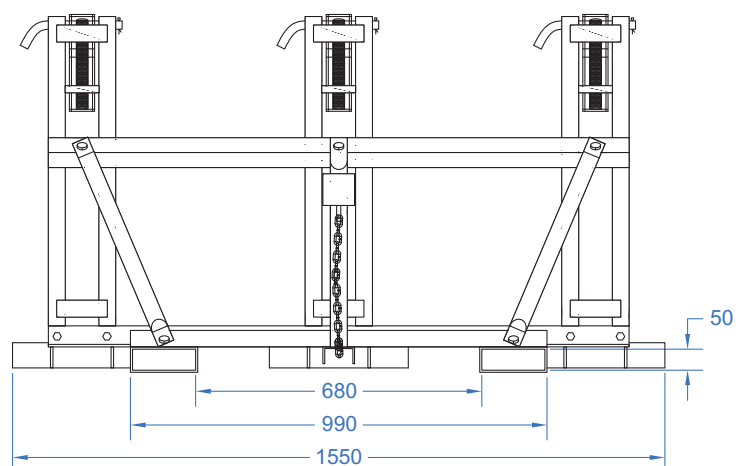
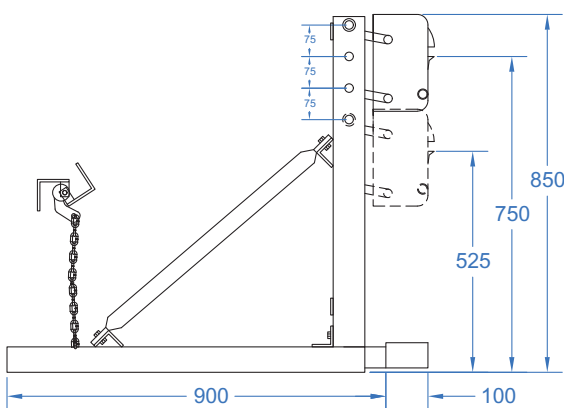

- Using the level principle
- Single operator can easily operate
- Widely used for transporting all kinds of rimmed drums

Model	Unit	DG360A	DG360B	DG360C	DG360D
Load	kg	360	360*2	360*3	360*4
net weight	kg	45	65	100	125

Note: There may be any specification/dimensional change. If these specifications are critical, the proposed application should be discussed.